



# Cambridge IGCSE™ (9–1)

CANDIDATE  
NAME

CENTRE  
NUMBER

|  |  |  |  |  |
|--|--|--|--|--|
|  |  |  |  |  |
|--|--|--|--|--|

CANDIDATE  
NUMBER

|  |  |  |  |
|--|--|--|--|
|  |  |  |  |
|--|--|--|--|



**CO-ORDINATED SCIENCES**

**0973/42**

Paper 4 Theory (Extended)

**May/June 2020**

**2 hours**

You must answer on the question paper.

No additional materials are needed.

## INSTRUCTIONS

- Answer **all** questions.
- Use a black or dark blue pen. You may use an HB pencil for any diagrams or graphs.
- Write your name, centre number and candidate number in the boxes at the top of the page.
- Write your answer to each question in the space provided.
- Do **not** use an erasable pen or correction fluid.
- Do **not** write on any bar codes.
- You may use a calculator.
- You should show all your working and use appropriate units.

## INFORMATION

- The total mark for this paper is 120.
- The number of marks for each question or part question is shown in brackets [ ].
- The Periodic Table is printed in the question paper.

This document has **32** pages. Blank pages are indicated.

1 (a) Fig. 1.1 is a photomicrograph of pollen from an insect-pollinated plant.

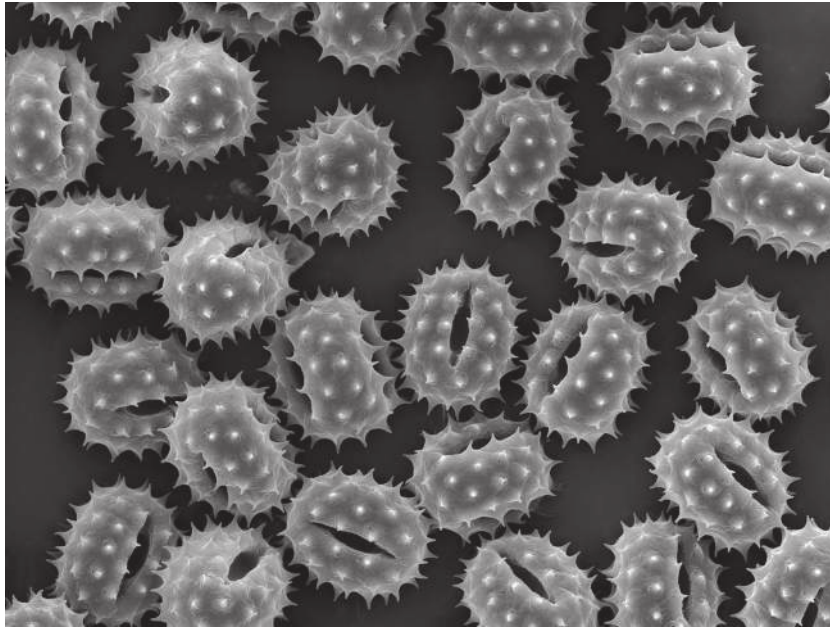
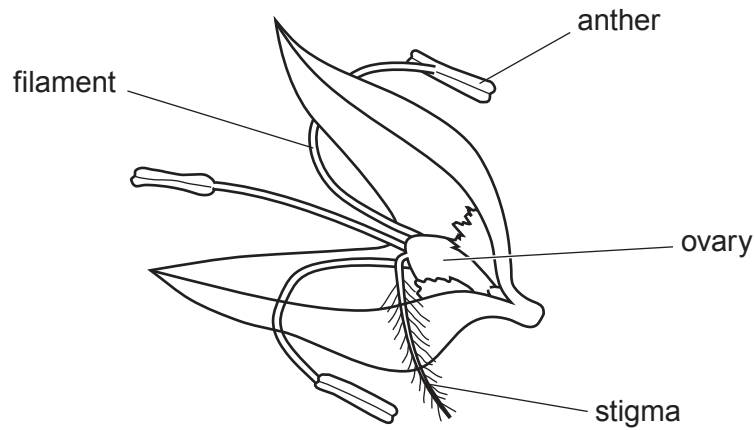

Fig. 1.1

Describe **one visible** piece of evidence that shows this pollen is from an insect-pollinated plant.

.....  
..... [1]

(b) Fig. 1.2 is a diagram of a flower from a wind-pollinated plant.



**Fig. 1.2**

Describe two ways the stigma shown in Fig. 1.2 is specialised for wind-pollination.

- 1 .....
- .....
- 2 .....
- .....

[2]

(c) Pollination is the transfer of pollen. This can lead to fertilisation.

Describe the process of fertilisation in plants.

- .....
- .....
- .....
- .....

[2]

(d) A species of flowering plant has 18 chromosomes in its mesophyll cells.

Deduce the number of chromosomes in its:

- male gametes in its pollen .....
- root hair cells. ....

[2]

(e) Plants can reproduce asexually or sexually.

Describe **one** advantage and **one** disadvantage of plants reproducing **asexually** in the wild.

advantage .....

.....

disadvantage .....

.....

[2]

[Total: 9]



2 (a) (i) Fig. 2.1 shows the three states of matter.

Complete the labels on Fig. 2.1.

[2]

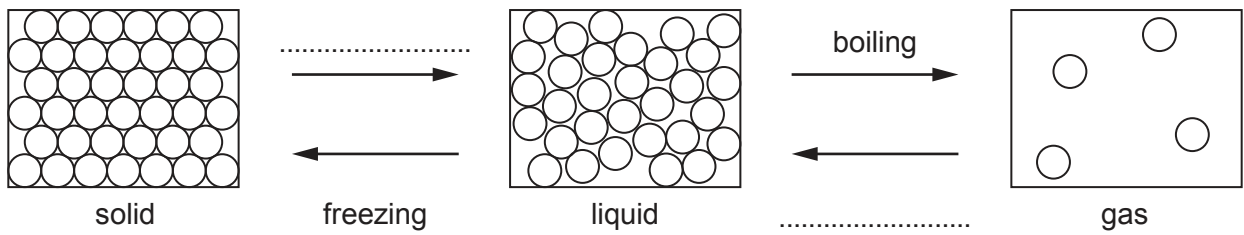

Fig. 2.1

(ii) Describe what happens to the total kinetic energy of the particles as the gas changes to a liquid and then to a solid.

..... [1]

(b) A scientist analyses an unknown ink sample and four dyes, A, B, C and D.

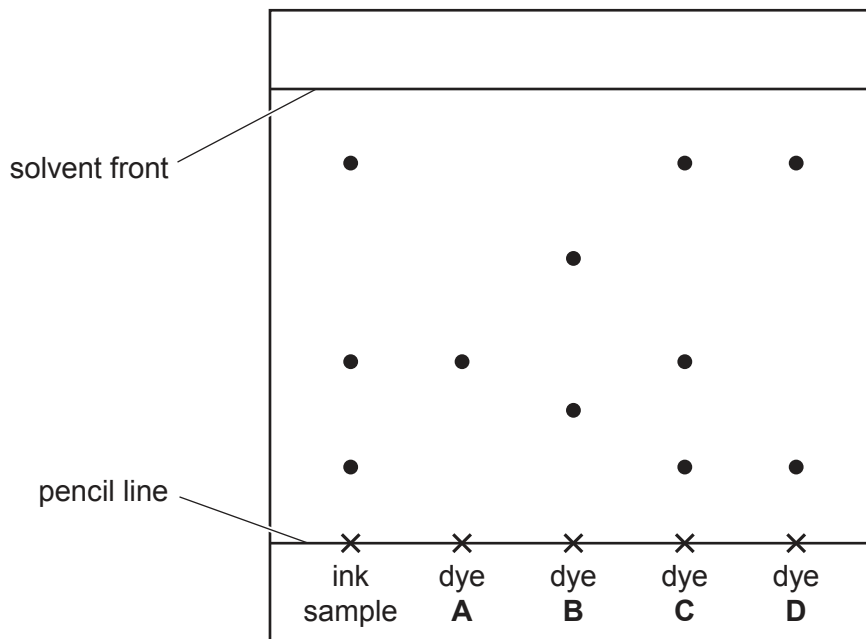

Fig. 2.2

Fig. 2.2 shows the chromatogram produced.

(i) Calculate the  $R_f$  value for dye A.

$R_f$  value = ..... [2]

(ii) State which dye **cannot** be in the ink sample.

Explain your answer.

dye .....

explanation .....

.....

.....

[2]

(iii) A solvent is used during chromatography.

Define the term *solvent*.

.....

..... [1]

(c) Table 2.1 shows the melting point of two substances, **X** and **Y**.

**Table 2.1**

| substance | melting point/°C |
|-----------|------------------|
| <b>X</b>  | 84               |
| <b>Y</b>  | 78–82            |

State which substance is pure.

Explain your answer.

pure substance .....

explanation .....

.....

[1]

[Total: 9]

- 3 (a) A car has two identical headlamps  $L_1$  and  $L_2$ .

The lamps are connected in parallel across a 12V battery as shown in Fig. 3.1.

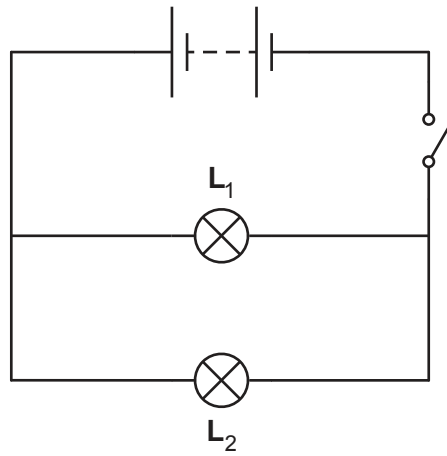

Fig. 3.1

- (i) The current passing through  $L_1$  is 5.0A.

Show that the resistance of  $L_1$  is  $2.4\Omega$ .

[2]

- (ii) Calculate the combined resistance of the two lamps connected in parallel.

resistance = .....  $\Omega$  [2]

- (iii) State one reason why the lamps are connected in parallel rather than in series.

.....  
 .....  
 ..... [1]



(b) The headlamps emit visible light. The frequency of some of this light is  $6.0 \times 10^{14}$  Hz.

Calculate the wavelength of this light.

wavelength = ..... m [3]

(c) The car engine is noisy and emits sound waves that pass through the air as a series of compressions and rarefactions.

Fig. 3.2 shows the positions of the compressions and rarefactions as the sound wave passes through the air.



Fig. 3.2

(i) On Fig. 3.2 label the centre of a rarefaction with the letter **R**. [1]

(ii) Explain in terms of compressions what is meant by the frequency of a sound wave.

.....  
..... [1]

(d) The steel radiator on the car transfers thermal energy through the radiator wall by conduction.

Describe how thermal energy passes through a metal by conduction.

.....  
.....  
.....  
.....  
..... [2]

[Total: 12]

4 (a) A student measures his breathing rate at rest and during exercise.

The results are shown in Table 4.1.

**Table 4.1**

| average breathing rate / number of breaths per minute |                 |
|---|-----------------|
| at rest   | during exercise |
| 14  | 62              |

(i) The student exercises for 30 minutes.

Calculate the average number of breaths taken during 30 minutes of exercise.

..... [1]

(ii) Explain the reasons for the difference in breathing rate shown in Table 4.1.

.....  
 .....  
 .....  
 .....  
 .....  
 .....  
 ..... [3]

(iii) Describe two ways that the composition of inspired air differs from expired air.

1 .....  
 2 ..... [2]

(b) Alveoli are the site of gas exchange.

One of the features of gas exchange surfaces is that they are surrounded by capillaries providing a good blood supply.

(i) List two other features of gas exchange surfaces in humans.

- 1 .....
- 2 ..... [2]

(ii) Describe how capillaries are adapted for their function.

- .....
- .....
- .....
- ..... [2]

[Total: 10]

5 Aluminium is used to make aircraft parts.

(a) State how aluminium is extracted from aluminium oxide.

..... [1]

(b) Explain why aluminium is used to make aircraft parts.

.....

.....

..... [2]

(c) Table 5.1 shows information about the reactions of some metals.

**Table 5.1**

| metal     | reaction with dilute hydrochloric acid  |
|-----------|---|
| gold      | no reaction                             |
| magnesium | reacts quickly to make hydrogen gas     |
| sodium    | reacts explosively to make hydrogen gas |
| tin       | reacts very slowly to make hydrogen gas |
| zinc      | reacts slowly to make hydrogen gas      |

(i) Use the information in Table 5.1 to complete the order of reactivity of the metals.

..... most reactive

.....

.....

.....

.....

..... least reactive [2]

(ii) Write a balanced symbol equation for the reaction of magnesium with hydrochloric acid, HCl.

..... [2]

(iii) Aluminium is more reactive than zinc.

When aluminium is added to cold dilute hydrochloric acid there appears to be no reaction.

Explain this apparent unreactivity.

.....  
.....  
..... [2]

[Total: 9]

6 The nuclear fuel used in some power stations is plutonium-239.

(a) (i) Plutonium-239 decays by  $\alpha$ -particle emission.

Use nuclide notation to complete the symbol equation for this decay process.



[3]

(ii) Plutonium-239 has a half-life of 24 000 years.

2 kg of plutonium-239 is sealed in a lead container.

Calculate the mass of plutonium-239 remaining after 120 000 years.

mass = ..... kg [2]

(b) The nuclear fuel releases  $8.6 \times 10^{13}$  J of energy.

From this, only  $3.2 \times 10^{13}$  J of electrical energy is generated.

Calculate the efficiency of this generation process.

efficiency = .....% [2]

(c) The power station generates electricity at 25 000 V.

A transformer increases this voltage to 400 000 V before the electricity is transmitted over large distances through transmission cables.

The number of turns on the secondary coil of the transformer is 500 000.

Calculate the number of turns on the primary coil of the transformer.

number of turns = ..... [2]

- (d) When electricity has been generated at the power station the voltage is increased by a transformer to reduce power losses in the transmission cables.

Explain why power losses in cables are lower when the voltage is high.

.....

.....

.....

..... [2]

[Total: 11]

7 (a) A lake is an example of an ecosystem.

Fig. 7.1 shows a food chain from a lake.

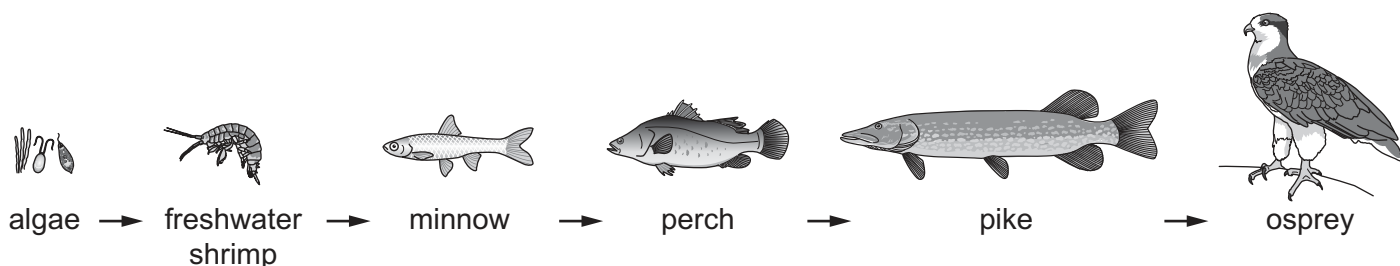

Fig. 7.1

(i) Identify the quaternary consumer in this food chain.

..... [1]

(ii) State the number of trophic levels in this food chain.

..... [1]

(iii) Explain why the number of trophic levels in this food chain is unusual.

.....  
 .....  
 .....  
 .....  
 .....  
 .....  
 ..... [3]



(b) Table 7.1 shows definitions for three terms related to the environment.

Complete Table 7.1 by adding the term that matches each definition.

**Table 7.1**

| definition   | term |
|--|------|
| a network of interconnected food chains                            |      |
| an organism that makes its own organic nutrients                   |      |
| an organism that gets its energy from dead or waste organic matter |      |

[3]

(c) A forest is also an ecosystem.

Deforestation has negative impacts on the environment.

Landslides are one example.

Fig. 7.2 is a photograph of a landslide.



**Fig. 7.2**

(i) Explain why deforestation can increase the chance of a landslide.

.....  
.....  
.....  
..... [2]

(ii) Describe how deforestation can lead to a decrease in the concentration of oxygen in the atmosphere.

.....  
.....  
.....  
..... [2]

[Total: 12]



- 8 Diamond and graphite are different forms of the element carbon.

Fig. 8.1 shows the structures of diamond and graphite.

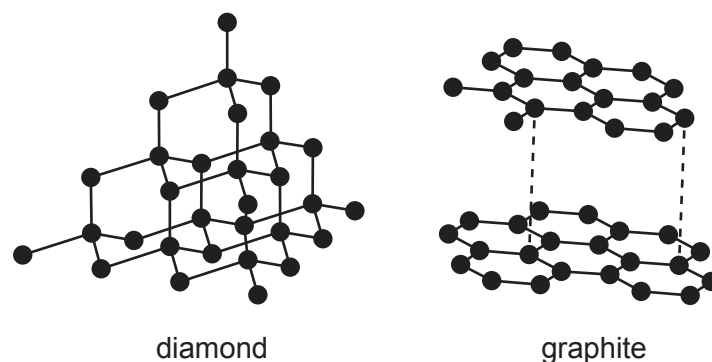

**Fig. 8.1**

- (a) (i) Diamond is used in cutting tools.

Explain why.

Use ideas about the structure and bonding in diamond.

.....

.....

..... [2]

- (ii) Graphite is used to make electrodes because it conducts electricity.

Explain why graphite conducts electricity.

Use ideas about the structure and bonding in graphite.

.....

.....

..... [2]

(b) Carbon can bond with hydrogen to form hydrocarbons.

Ethene, C<sub>2</sub>H<sub>4</sub>, is a hydrocarbon.

Draw a dot-and-cross diagram to show the bonding in ethene.

Show all of the outer shell electrons. Do **not** show the inner electrons.

[2]

(c) Ethene burns in oxygen to form carbon dioxide.

Carbon dioxide is a greenhouse gas.

State an effect of increased concentrations of greenhouse gases in the atmosphere.

..... [1]

(d) Carbon monoxide is made in a car engine.

The carbon monoxide is removed by a catalytic converter.

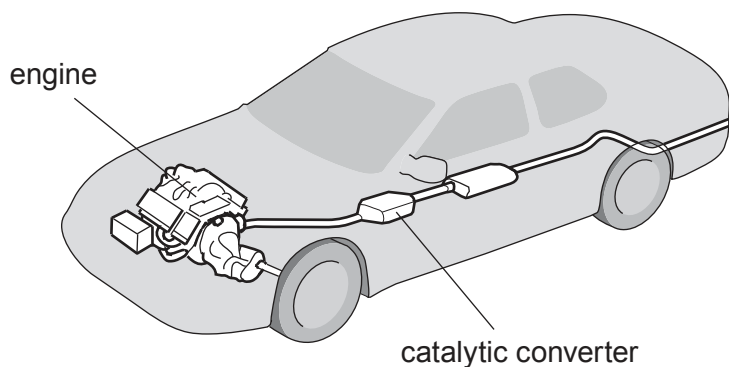

**Fig. 8.2**

Describe how a catalytic converter removes carbon monoxide.

Include a **balanced symbol** equation in your answer.

..... [3]

[Total: 10]

**[Turn over**

9 A mountaineer climbs a mountain.

(a) At the top of the mountain there is some ice that is melting in the sunshine.

(i) State the melting point of water. .... °C [1]

(ii) Describe, in terms of molecular motion and arrangement, how liquid water is different from ice.

motion .....

.....

arrangement .....

..... [2]

(b) On the mountain, the mountaineer is exposed to ultraviolet radiation.

Ultraviolet radiation is an electromagnetic wave.

On Fig. 9.1 write ultraviolet in the correct place in the incomplete electromagnetic spectrum.

|  |        |  |               |  |  |             |
|--|--------|--|---------------|--|--|-------------|
|  | X-rays |  | visible light |  |  | radio waves |
|--|--------|--|---------------|--|--|-------------|

Fig. 9.1

[1]

(c) The mountaineer observes lightning striking a nearby mountain.

(i) There is an electric field between the negative charge on a cloud and the positive charge on the mountain.

State what is meant by an *electric field*.

.....

..... [1]

(ii) The lightning occurs when the cloud loses some of its charge to the mountain.

The lightning flash discharges 3.0 C in 0.00012 s.

Calculate the current that passes.

current = ..... A [2]

[Total: 7]

10 (a) Fig. 10.1 is a sketch graph showing the effect of temperature on the rate of transpiration (loss of water from leaves).

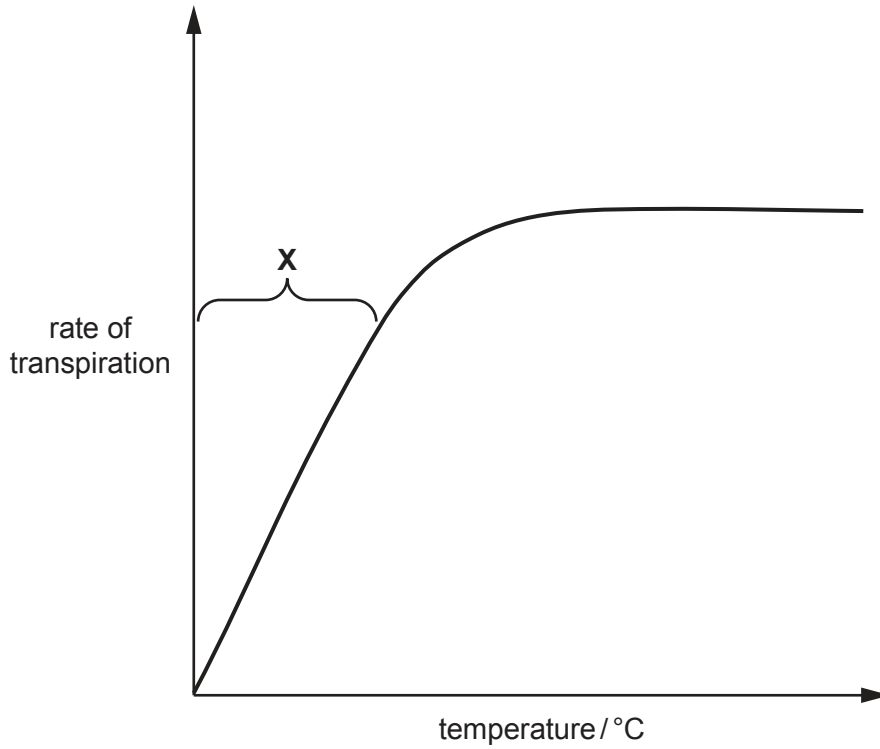

Fig. 10.1

(i) Explain the trend seen in the part of the graph labelled X.

Include in your answer a reference to water molecules and the name of the part of the leaf where transpiration occurs.

.....  
.....  
.....  
.....  
.....  
..... [3]

(ii) State one other factor that affects the rate of transpiration.

..... [1]

(b) Table 10.1 compares transpiration with translocation.

**Table 10.1**

|                                   | transpiration        | translocation      |
|-----------------------------------|----------------------|--------------------|
| substances moved                  | water                | 1 .....<br>2 ..... |
| direction of movement             | from roots to leaves |                    |
| name of tissue used for transport |                      |                    |

Complete Table 10.1.

[3]

(c) State the balanced symbol equation for photosynthesis.

..... [2]

[Total: 9]



11 Ammonium sulfate is used as a fertiliser.

(a) Ammonium sulfate contains the ions  $\text{NH}_4^+$  and  $\text{SO}_4^{2-}$ .

Determine the formula of ammonium sulfate.

..... [1]

(b) Describe why it is important that farmers use fertilisers containing nitrogen, phosphorus and potassium.

.....  
.....  
..... [2]

(c) Ammonium sulfate is made by reacting dilute sulfuric acid with ammonia.

Ammonia is made in the Haber process.

Nitrogen gas reacts with hydrogen gas as shown in the equation.

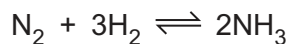

(i) Explain why a temperature of 450 °C is used rather than a temperature of 800 °C. Do **not** include cost in your answer.

.....  
..... [1]

(ii) Explain why a temperature of 450 °C is used rather than a temperature of 200 °C. Do **not** include cost in your answer.

.....  
..... [1]

(iii) State why iron is needed in the Haber process.

.....  
..... [1]

[Total: 6]

12 (a) A cyclist accelerates along a straight road from a speed of 4 m/s to maximum speed.

The combined mass of the cyclist and bicycle is 80 kg.

Fig. 12.1 is the speed-time graph for the bicycle and cyclist.

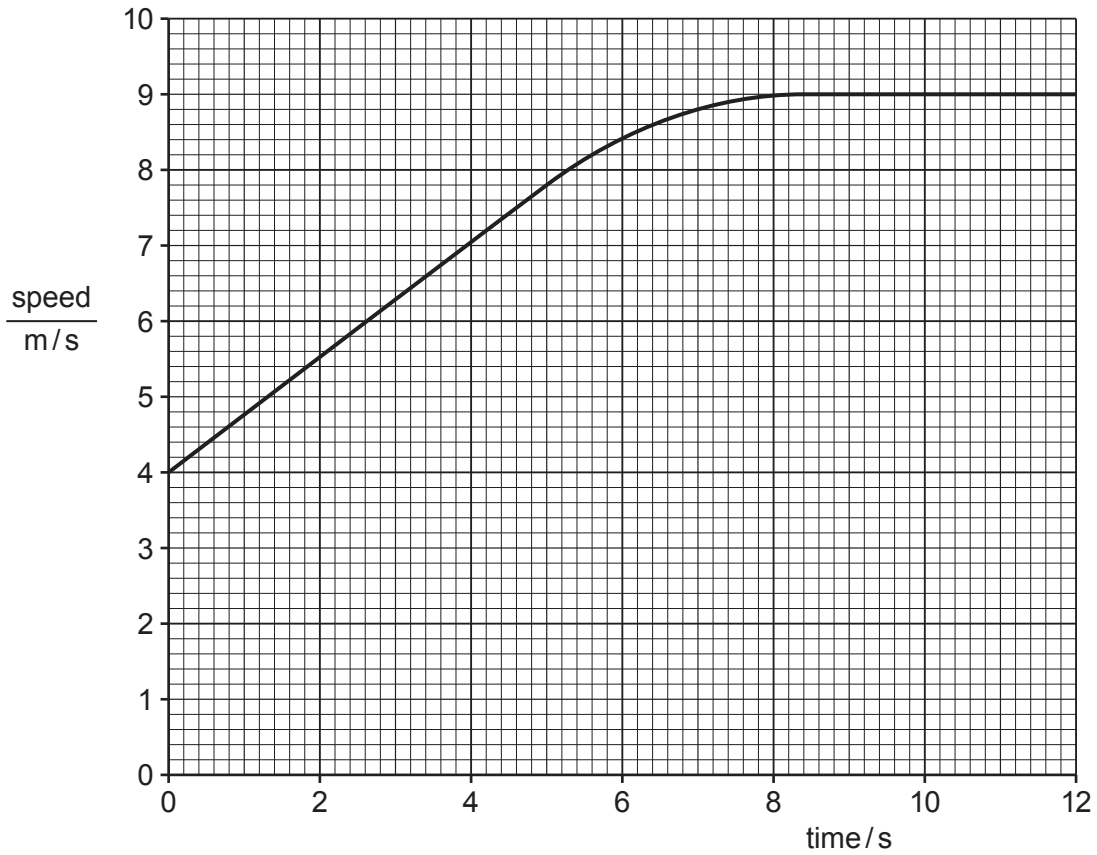

Fig. 12.1

(i) Use Fig. 12.1 to calculate the acceleration at 2 s.

Show your working.

acceleration = ..... m/s<sup>2</sup> [2]

(ii) Calculate the resultant force acting on the cyclist and bicycle during this acceleration.

force = ..... N [2]

- (iii) Calculate the maximum kinetic energy of the cyclist and bicycle during the 12 second period in Fig. 12.1.

kinetic energy = ..... J [3]

- (b) Fig. 12.2 shows a section through a plastic reflector on the bicycle. A ray of light from a car is incident on the flat surface of the reflector.

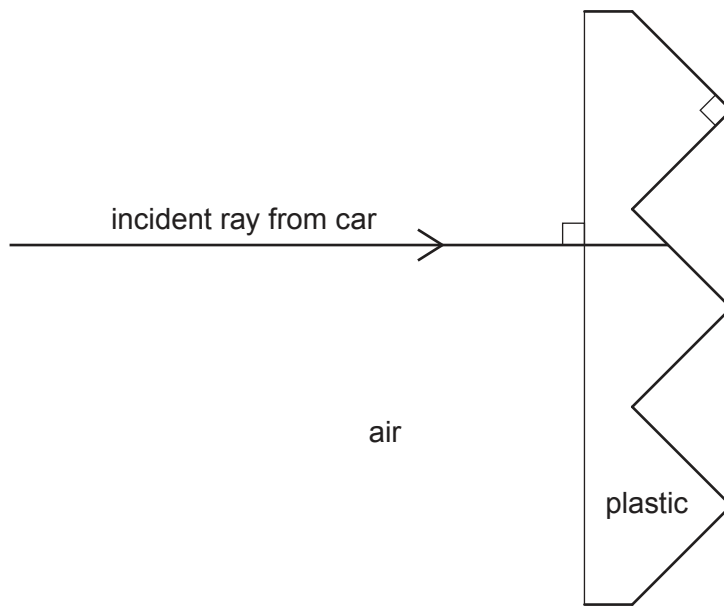

Fig. 12.2

The incident ray is totally internally reflected.

Continue the incident ray on Fig. 12.2 to show the path of the ray of light until it leaves the reflector. [2]

(c) Fig. 12.3 shows a metal nut on the bicycle wheel.

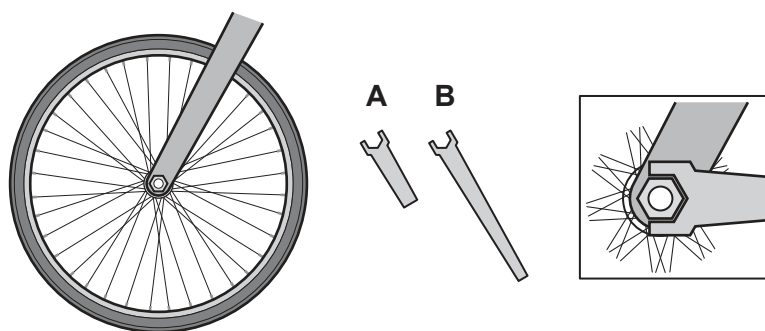

Fig. 12.3

The nut must be turned by either spanner **A** or spanner **B**.

State why spanner **B** will turn the nut more easily than spanner **A**.

..... [1]

[Total: 10]

13 Polymers are made from small molecules called monomers.

(a) The structure of a polymer is shown.

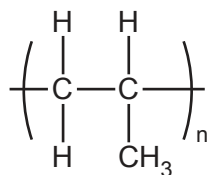

Draw the structure of the monomer.

[1]

(b) Poly(ethene) is an **addition** polymer.

Nylon is a **condensation** polymer.

Describe the differences between addition polymerisation and condensation polymerisation.

.....

.....

.....

..... [2]

(c) A mixture containing 3.9 g of ethene and 4.0 g of steam is allowed to react.

Ethanol,  $C_2H_6O$ , is made.



Determine the **limiting reactant** in this reaction.

Show your working and explain your answer.

[ $A_r$ : C, 12; H, 1; O, 16]

limiting reactant .....

explanation .....

.....

[3]

[Total: 6]

**BLANK PAGE**

---

Permission to reproduce items where third-party owned material protected by copyright is included has been sought and cleared where possible. Every reasonable effort has been made by the publisher (UCLES) to trace copyright holders, but if any items requiring clearance have unwittingly been included, the publisher will be pleased to make amends at the earliest possible opportunity.

To avoid the issue of disclosure of answer-related information to candidates, all copyright acknowledgements are reproduced online in the Cambridge Assessment International Education Copyright Acknowledgements Booklet. This is produced for each series of examinations and is freely available to download at [www.cambridgeinternational.org](http://www.cambridgeinternational.org) after the live examination series.

Cambridge Assessment International Education is part of the Cambridge Assessment Group. Cambridge Assessment is the brand name of the University of Cambridge Local Examinations Syndicate (UCLES), which itself is a department of the University of Cambridge.

## The Periodic Table of Elements

|                                   |                                    | Group  |                                    |                                    |                                     |                                    |                                     |                                   |                                     |                                  |                                   |                                    |                                    |                                    |                                     |                                     |                                  |                                     |                                  |                                       |                                   |  |                                     |                                    |                                    |                                    |                                      |                                   |                                      |                                     |                                  |                                      |                                     |                                     |
|-----------------------------------|------------------------------------|--|------------------------------------|------------------------------------|-------------------------------------|------------------------------------|-------------------------------------|-----------------------------------|-------------------------------------|----------------------------------|-----------------------------------|------------------------------------|------------------------------------|------------------------------------|-------------------------------------|-------------------------------------|----------------------------------|-------------------------------------|----------------------------------|---------------------------------------|-----------------------------------|--|-------------------------------------|------------------------------------|------------------------------------|------------------------------------|--------------------------------------|-----------------------------------|--------------------------------------|-------------------------------------|----------------------------------|--------------------------------------|-------------------------------------|-------------------------------------|
| I                                 | II                                 | III  | IV                                 | V                                  | VI                                  | VII                                | VIII                                |                                   |                                     |                                  |                                   |                                    |                                    |                                    |                                     |                                     |                                  |                                     |                                  |                                       |                                   |  |                                     |                                    |                                    |                                    |                                      |                                   |                                      |                                     |                                  |                                      |                                     |                                     |
| 3<br><b>Li</b><br>lithium<br>7    | 4<br><b>Be</b><br>beryllium<br>9   | 1<br><b>H</b><br>hydrogen<br>1   | 5<br><b>B</b><br>boron<br>11       | 6<br><b>C</b><br>carbon<br>12      | 7<br><b>N</b><br>nitrogen<br>14     | 8<br><b>O</b><br>oxygen<br>16      | 9<br><b>F</b><br>fluorine<br>19     | 10<br><b>Ne</b><br>neon<br>20     |                                     |                                  |                                   |                                    |                                    |                                    |                                     |                                     |                                  |                                     |                                  |                                       |                                   |  |                                     |                                    |                                    |                                    |                                      |                                   |                                      |                                     |                                  |                                      |                                     |                                     |
| 11<br><b>Na</b><br>sodium<br>23   | 12<br><b>Mg</b><br>magnesium<br>24 | <b>Key</b><br>atomic number<br>atomic symbol<br>name<br>relative atomic mass |                                    |                                    |                                     |                                    |                                     |                                   |                                     |                                  |                                   |                                    |                                    |                                    |                                     |                                     |                                  |                                     |                                  |                                       |                                   |  |                                     |                                    |                                    |                                    |                                      |                                   |                                      |                                     |                                  |                                      |                                     |                                     |
| 19<br><b>K</b><br>potassium<br>39 | 20<br><b>Ca</b><br>calcium<br>40   |  |                                    |                                    |                                     |                                    |                                     |                                   |                                     |                                  |                                   | 13<br><b>Al</b><br>aluminium<br>27 | 14<br><b>Si</b><br>silicon<br>28   | 15<br><b>P</b><br>phosphorus<br>31 | 16<br><b>S</b><br>sulfur<br>32      | 17<br><b>Cl</b><br>chlorine<br>35.5 | 18<br><b>Ar</b><br>argon<br>40   |                                     |                                  |                                       |                                   |  |                                     |                                    |                                    |                                    |                                      |                                   |                                      |                                     |                                  |                                      |                                     |                                     |
| 37<br><b>Rb</b><br>rubidium<br>85 | 38<br><b>Sr</b><br>strontium<br>88 | 21<br><b>Sc</b><br>scandium<br>45  | 22<br><b>Ti</b><br>titanium<br>48  | 23<br><b>V</b><br>vanadium<br>51   | 24<br><b>Cr</b><br>chromium<br>52   | 25<br><b>Mn</b><br>manganese<br>55 | 26<br><b>Fe</b><br>iron<br>56       | 27<br><b>Co</b><br>cobalt<br>59   | 28<br><b>Ni</b><br>nickel<br>59     | 29<br><b>Cu</b><br>copper<br>64  | 30<br><b>Zn</b><br>zinc<br>65     | 31<br><b>Ga</b><br>gallium<br>70   | 32<br><b>Ge</b><br>germanium<br>73 | 33<br><b>As</b><br>arsenic<br>75   | 34<br><b>Se</b><br>selenium<br>79   | 35<br><b>Br</b><br>bromine<br>80    | 36<br><b>Kr</b><br>krypton<br>84 |                                     |                                  |                                       |                                   |  |                                     |                                    |                                    |                                    |                                      |                                   |                                      |                                     |                                  |                                      |                                     |                                     |
| 55<br><b>Cs</b><br>caesium<br>133 | 56<br><b>Ba</b><br>barium<br>137   | 39<br><b>Y</b><br>yttrium<br>89  | 40<br><b>Zr</b><br>zirconium<br>91 | 41<br><b>Nb</b><br>niobium<br>93   | 42<br><b>Mo</b><br>molybdenum<br>96 | 43<br><b>Tc</b><br>technetium<br>— | 44<br><b>Ru</b><br>ruthenium<br>101 | 45<br><b>Rh</b><br>rhodium<br>103 | 46<br><b>Pd</b><br>palladium<br>106 | 47<br><b>Ag</b><br>silver<br>108 | 48<br><b>Cd</b><br>cadmium<br>112 | 49<br><b>In</b><br>indium<br>115   | 50<br><b>Sn</b><br>tin<br>119      | 51<br><b>Sb</b><br>antimony<br>122 | 52<br><b>Te</b><br>tellurium<br>128 | 53<br><b>I</b><br>iodine<br>127     | 54<br><b>Xe</b><br>xenon<br>131  | 55<br><b>Fr</b><br>francium<br>—    | 56<br><b>Ra</b><br>radium<br>—   | 57<br><b>La</b><br>lanthanoids<br>139 | 58<br><b>Ce</b><br>cerium<br>140  | 59<br><b>Pr</b><br>praseodymium<br>141 | 60<br><b>Nd</b><br>neodymium<br>144 | 61<br><b>Pm</b><br>promethium<br>— | 62<br><b>Sm</b><br>samarium<br>150 | 63<br><b>Eu</b><br>europium<br>152 | 64<br><b>Gd</b><br>gadolinium<br>157 | 65<br><b>Tb</b><br>terbium<br>159 | 66<br><b>Dy</b><br>dysprosium<br>163 | 67<br><b>Ho</b><br>holmium<br>165   | 68<br><b>Er</b><br>erbium<br>167 | 69<br><b>Tm</b><br>thulium<br>169    | 70<br><b>Yb</b><br>ytterbium<br>173 | 71<br><b>Lu</b><br>lutetium<br>175  |
| 87<br><b>Fr</b><br>francium<br>—  | 88<br><b>Ra</b><br>radium<br>—     | 89–103<br>actinoids  | 72<br><b>Hf</b><br>hafnium<br>178  | 73<br><b>Ta</b><br>tantalum<br>181 | 74<br><b>W</b><br>tungsten<br>184   | 75<br><b>Re</b><br>rhenium<br>186  | 76<br><b>Os</b><br>osmium<br>190    | 77<br><b>Ir</b><br>iridium<br>192 | 78<br><b>Pt</b><br>platinum<br>195  | 79<br><b>Au</b><br>gold<br>197   | 80<br><b>Hg</b><br>mercury<br>201 | 81<br><b>Tl</b><br>thallium<br>204 | 82<br><b>Pb</b><br>lead<br>207     | 83<br><b>Bi</b><br>bismuth<br>209  | 84<br><b>Po</b><br>polonium<br>—    | 85<br><b>At</b><br>astatine<br>—    | 86<br><b>Rn</b><br>radon<br>—    | 87<br><b>La</b><br>lanthanum<br>139 | 88<br><b>Ce</b><br>cerium<br>140 | 89<br><b>Ac</b><br>actinium<br>—      | 90<br><b>Th</b><br>thorium<br>232 | 91<br><b>Pa</b><br>protactinium<br>231 | 92<br><b>U</b><br>uranium<br>238    | 93<br><b>Np</b><br>neptunium<br>—  | 94<br><b>Pu</b><br>plutonium<br>—  | 95<br><b>Am</b><br>americium<br>—  | 96<br><b>Cm</b><br>curium<br>—       | 97<br><b>Bk</b><br>berkelium<br>— | 98<br><b>Cf</b><br>californium<br>—  | 99<br><b>Es</b><br>einsteinium<br>— | 100<br><b>Fm</b><br>fermium<br>— | 101<br><b>Md</b><br>mendelevium<br>— | 102<br><b>No</b><br>nobelium<br>—   | 103<br><b>Lr</b><br>lawrencium<br>— |

lanthanoids

actinoids

The volume of one mole of any gas is 24 dm<sup>3</sup> at room temperature and pressure (r.t.p.).